

Enquiry for Cutback Brushes

Drawing / description of application

[Grid area for drawing and description]

Piece number _____

Brush Application dry wet

removal of pipe coatings

others _____

Material to be treated _____ °C Temperature

steel

stainless steel

others _____

Filling material

steel

brass coated steel

stainless steel

Diameter of filling material: _____

Please indicate the dimensions according to the technical drawing (mm):

D Diameter _____ mm

DB bore _____ mm

DKN double keyway _____ mm

H trim height _____ mm

A working width _____ mm

Z number of knots _____ pcs.

EBR clamping width _____ mm

Knot type

B Rose Bud

O Open Knot (wire ends are cut)

D Fully knotted (wire ends are cut completely)

Used machine

stationary machine, Type _____

others _____

Machine data

max. speed _____

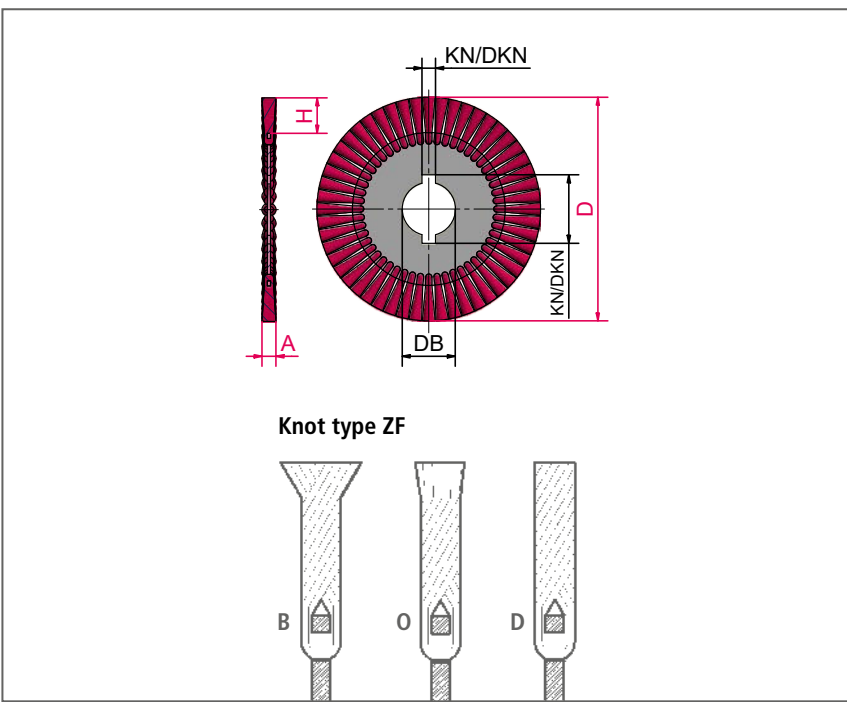

Sender: Company, contact person

[Blank space for sender information]

Inquiries and Infos:

Phone: +49 9082 707-0

info@lessmann.com

Fax: +49 9082 707-76

www.lessmann.com

