

Enquiry for Cup and Bevel Brushes

Drawing / description of application

Grid area for drawing or description of application.

Piece number _____

Brush Application dry wet

- derusting
- removing paint
- deburring
- cleaning
- weld dressing
- others _____

Material to be treated ____ °C Temperature

- steel
- aluminium
- stainless steel
- others _____

Filling material

- crimped knotted
- steel
- brass coated steel
- brass
- stainless steel
- silicon carbide bristles (SIC)

Diameter of filling material _____

Please indicate the dimensions according to the technical drawing (mm):

- D Diameter _____ mm
- DB/GI bore/thread _____ mm
- H trim height _____ mm
- A working width _____ mm
- H1 Height of support cuff _____ mm

Used machine

- hand-operated machine (e.g. angle grinders) _____
- stationary machine (z.B. CNC) _____
- others _____

Machine data

- max. speed _____
- max. brush height _____ mm

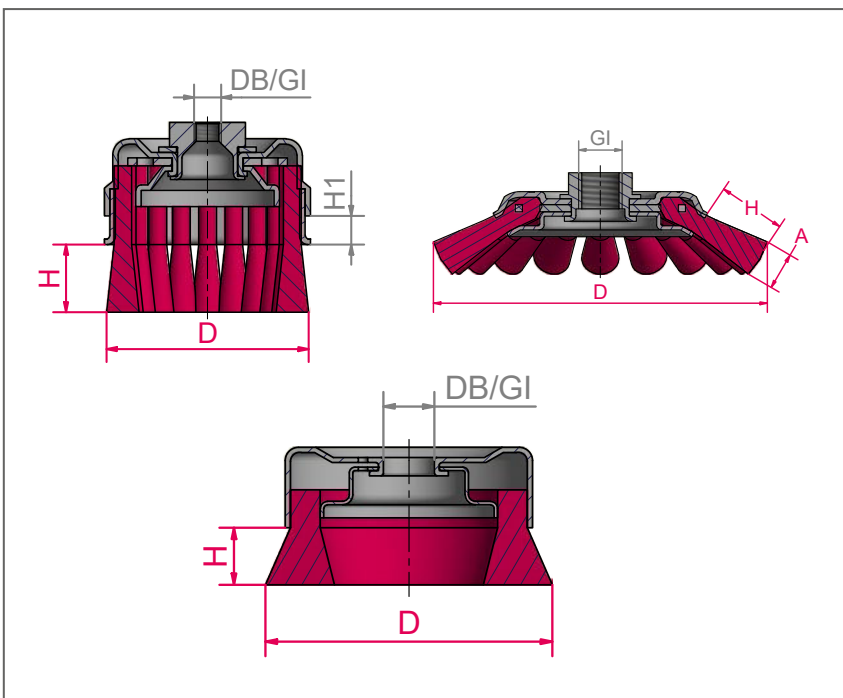

Sender: Company, contact person

Blank area for sender information.

Inquiries and Infos:

Phone: +49 9082 707-0 info@lessmann.com
 Fax: +49 9082 707-76 www.lessmann.com

